

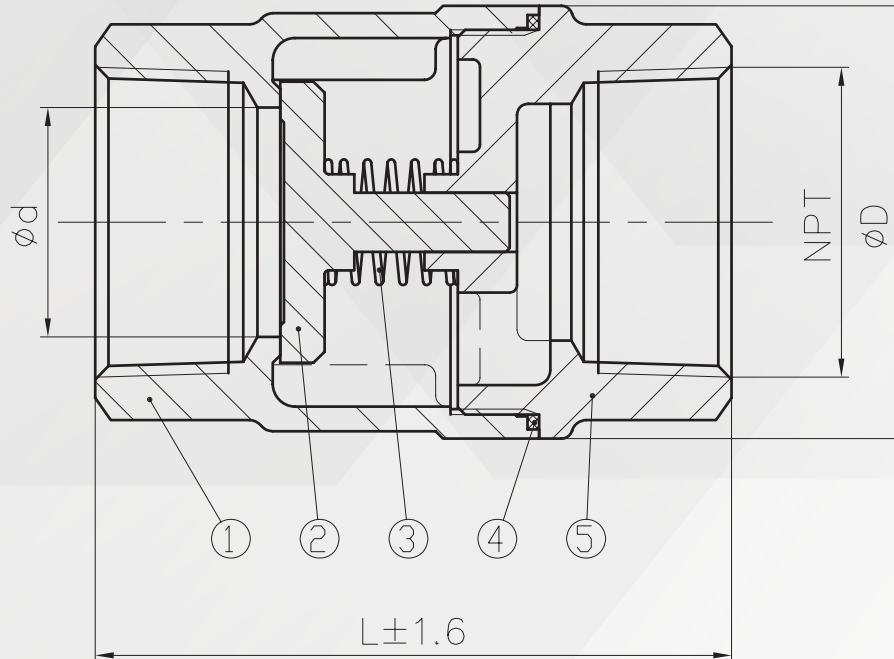

ANIX VALVE CO.LTD, Certified ISO 9001.
www.anixusa.com

Installation, Operation, and Maintenance (IOM) Manual for Spring Check Valve Threaded NPT



5	BONNET
4	GASKET
3	SPRING
2	DISC
1	BODY

Refer to the diagram and parts list above for a detailed view of each component, assisting with installation, operation, and maintenance for optimal valve performance.



ANIX VALVE CO.LTD, Certified ISO 9001.

www.anixusa.com

Note: This document is a general guideline for the installation, operation, and maintenance of Threaded Spring Check Valves, intended to assist trained personnel in following recommended procedures. It is not an exhaustive set of instructions. Carefully read the manual for safe and efficient use. We are not liable for damages arising from its use. Consult a professional if you have specific concerns related to your application or environment. For additional assistance, contact your supplier or representative.

PRODUCT OVERVIEW

- The Spring Check Valve with Threaded NPT connections is designed to provide reliable performance by allowing fluid to flow in one direction while preventing reverse flow. Its durable construction and compact design make it suitable for a wide range of applications, including industrial, residential, and commercial piping systems.

INSTALLATION

- **Orientation:** Install the valve in a horizontal pipeline with the valve body positioned vertically. Alternatively, it may be installed in a vertical pipeline, provided the flow arrow on the valve body points upwards.
- **Flow Direction:** Ensure the flow arrow on the body matches the direction of fluid flow.
- **Thread Preparation:** Apply a suitable joint compound or TFE tape to the male pipe threads to facilitate a secure and leak-free fit.
- **Good Piping Practice:** Follow standard piping practices to prevent misalignment or undue stress on the valve during installation.

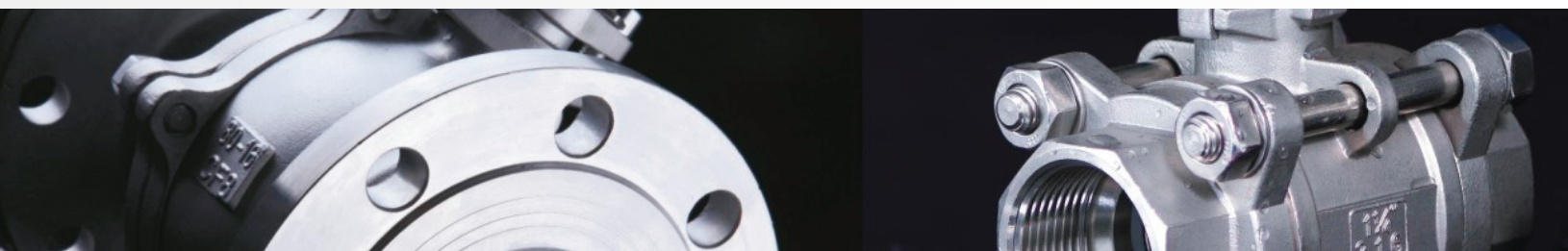



ANIX VALVE CO.LTD, Certified ISO 9001.
www.anixusa.com

OPERATION

- Automatic Operation: Swing check valves operate automatically; no manual action is required during normal use.
- Flow Control: These valves allow flow in only one direction and prevent backflow. The direction of permissible flow is indicated by the arrow on the valve body.

MAINTENANCE

- *****WARNING***** Do not attempt to perform maintenance on a valve while it is under pressure or in a pressurized line.
- Routine Service: These valves do not require lubrication, adjustment, or any preventive maintenance under normal service conditions.
- Replacement: If the valve disc or seat exhibits wear that compromises performance, the entire valve should be replaced.
- Inspection: Periodic visual checks can be conducted to ensure the valve is functioning as intended and free from debris.

